



Universidades Lusíada

Pitt, Roger

New town hall of Garnich

<http://hdl.handle.net/11067/408>

Metadados

Data de Publicação	2010
Resumo	O projecto para o novo edifício municipal de Garnich, no Luxemburgo, compreende a renovação de uma antiga casa agrícola e um novo acrescento. O edifício situa-se na zona antiga da localidade e assim desejou-se manter o seu aspecto rural e tradicional articulado com uma linguagem contemporânea não agressiva. Os novos elementos estruturantes e o design dos interiores adaptaram-se às novas funções mantendo o mais possível dos sistemas construtivos e pormenores arquitectónicos originais, comum cuida...
Palavras Chave	Edifícios rurais - Reforma para outro uso - Luxemburgo - Garnich, Edifícios municipais - Luxemburgo - Garnich
Tipo	article
Revisão de Pares	Não
Coleções	[ULL-FAA] RAL, n. 1 (2.º semestre 2010)

Esta página foi gerada automaticamente em 2024-04-28T00:57:14Z com informação proveniente do Repositório

NEW TOWN HALL OF GARNICH

Roger Pitt

RESUMO

O projecto para o novo edifício municipal de Garnich, no Luxemburgo, compreende a renovação de uma antiga casa agrícola e um novo acrescento. O edifício situa-se na zona antiga da localidade e assim desejou-se manter o seu aspecto rural e tradicional articulado com uma linguagem contemporânea não agressiva. Os novos elementos estruturantes e o design dos interiores adaptaram-se às novas funções mantendo o mais possível dos sistemas construtivos e pormenores arquitectónicos originais, com um cuidado especial nas exigências de conforto térmico e ambiental, com baixos consumos de energia e soluções que permitam ganhos energéticos.

PALAVRAS-CHAVE

Garnish; Projecto; Renovação.

ABSTRACT

The project for a new town hall for the commune of Garnich in Luxembourg comprised a renovation of an old farm house and a new extension. The building is located in the historic center of Garnich, so there was a desire to conserve most of the traditional and rural aspects; therefore the historic house has been renovated with this in mind.

All new structural elements and the interior design have been adapted to the new function of the building, keeping as much as possible of the original walls and materials. The exterior volume has been kept, also the old stone window sills and framing, while the slate roof has been renovated using the same materials and techniques, and thermally insulated.

KEY-WORDS

Garnish; Project; Renovation.

The new extension replaces the old barn attached to the farm house, respecting the original volumetry. The original barn gateway is reinserted in the new facade, but all window framing around the new windows were designed in a contemporary language, thus expressing a contrast between the new extension and the old farm house. These new window frames are a modern version of the window frames in stone of the old house, reinterpreting the traditional language of the existing framing. Their form and dimensions result from the function and needs of the office spaces inside the new extension. The same language and materials has been applied in the redesign of the bus stop in front of the town hall.

Great care was given to the interior atmospheres, and all light fittings create a warm ambience in entrance spaces and corridors, but having a maximum of efficiency in the office spaces. Also in the

interiors, a limited quantity of high quality materials were used, the predominant material for doors and floors of the new extension being oak in its natural color. Most of the materials in the existing house were conserved and renovated. Local splashes of color were integrated in the concept in order to have a striking contrast to the natural oak and the white surfaces of the walls and ceilings.

Ecological criteria had a high importance in the design of the building and all technical equipment. The roof of the old building has been thermally insulated, and new wooden windows in the building extension are double-glazed according to current technical standards. This new building extension has an efficient thermal insulation, and the south- and west-orientated elevations have been equipped with panels for sun protection. Photovoltaic panels were installed on the south-orientated part of the roof and a 10.000 liter cistern to collect rain water was integrated in the project.

Design: 2005 - 2007 Construction: 2007 - 2009 Gross surface: 1200 m²



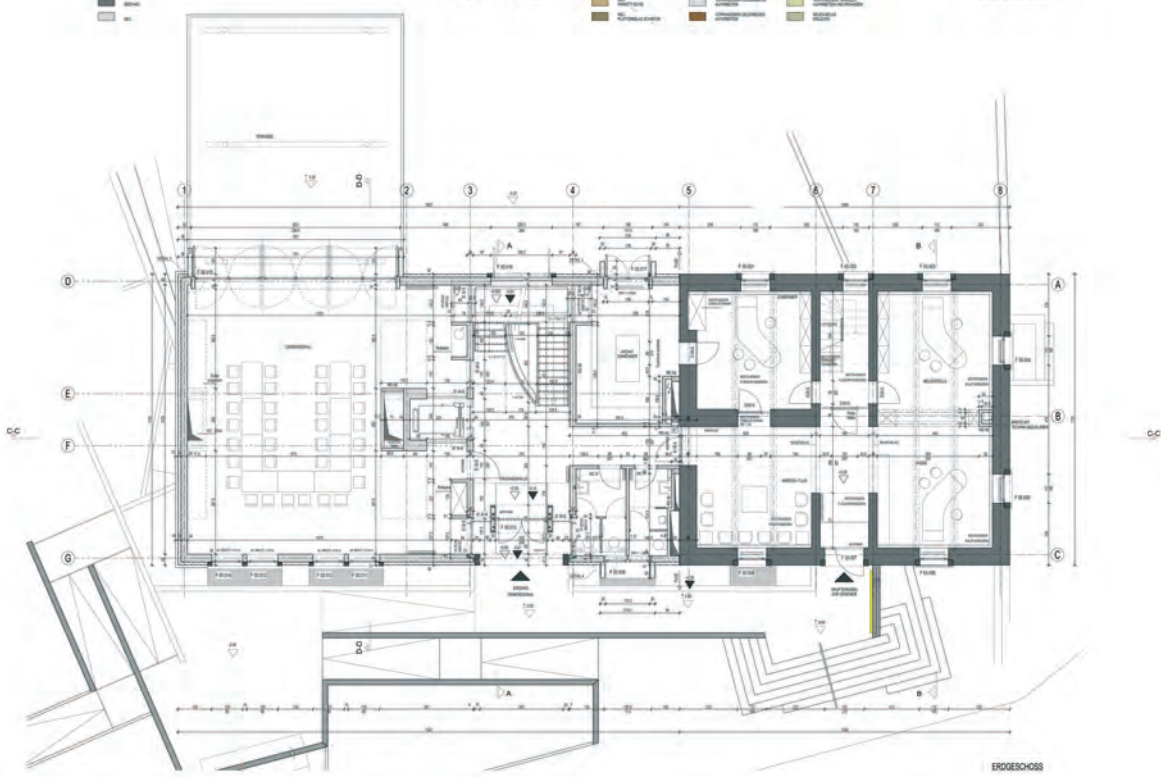
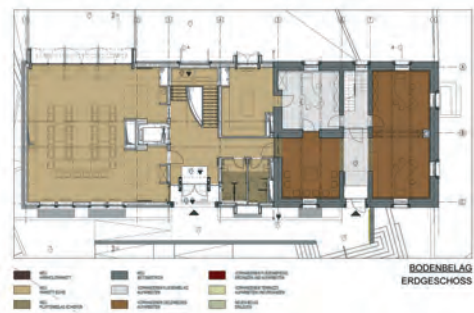
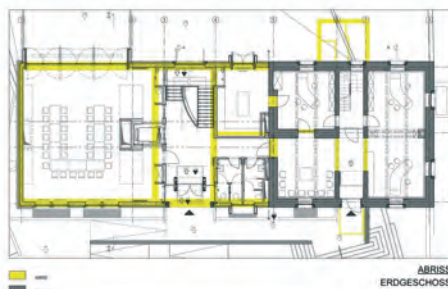

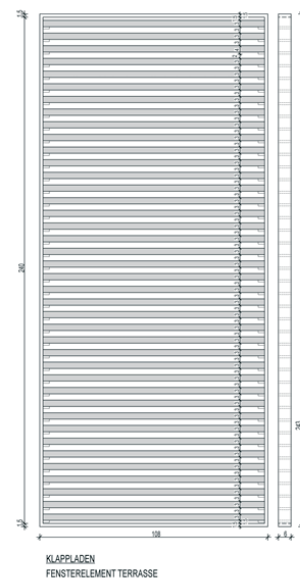
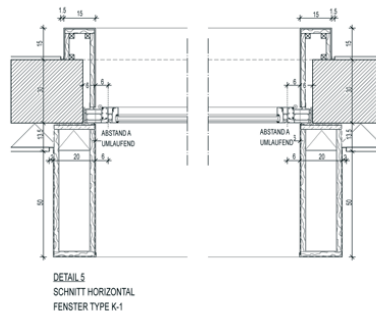
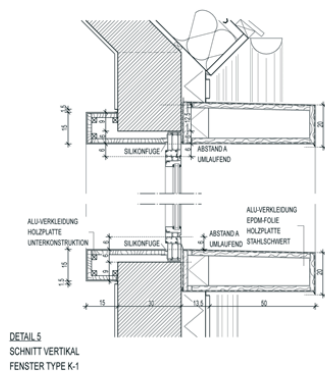
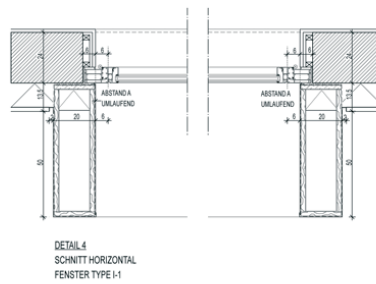
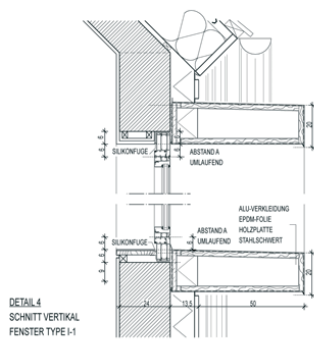
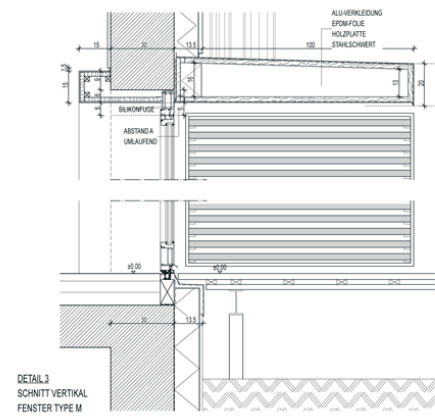
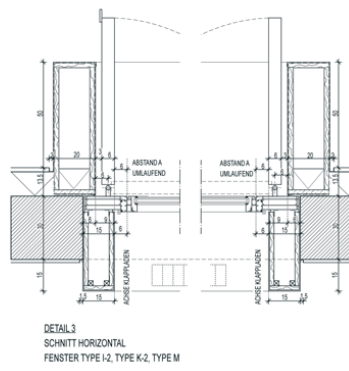
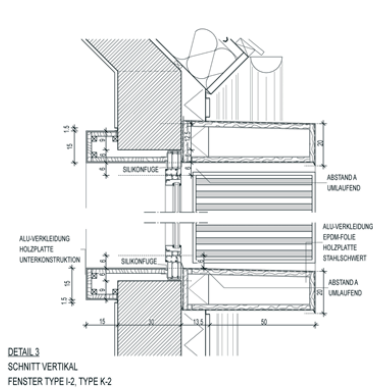

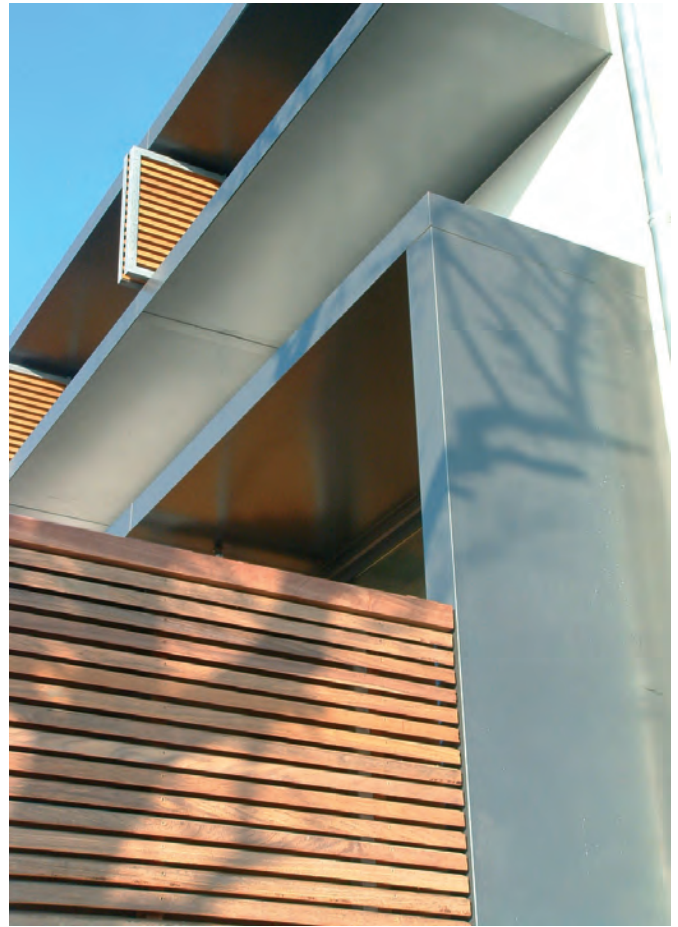

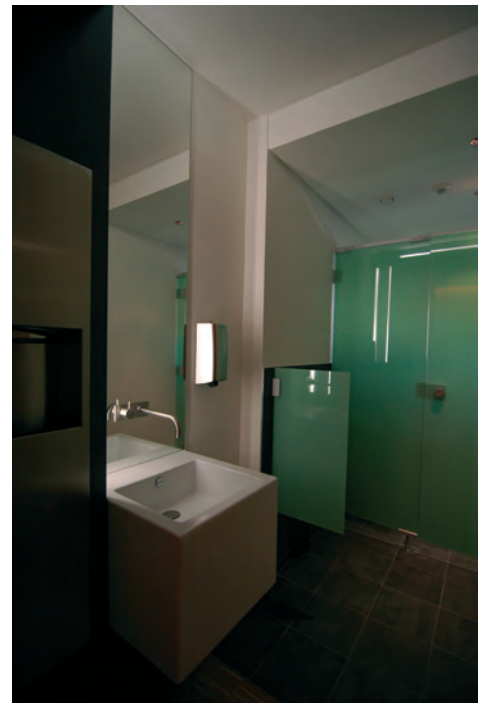











Roger Pitt

Estabelecido desde 1980 na cidade de Luxemburgo, o ateliê “Ballini Pitt & partners” integra uma vintena de colaboradores e conta com vasta produção internacional.

Os fundadores, Roger Pitt, arquitecto diplomado em 1977 pela Universidade de Sheffield (GB) e Gilbert Ballini, diplomado em 1978 pelo Institut Supérieur d’ Architecture de Liège (Bélgica) definiram desde início linhas orientadoras para os projectos baseadas em soluções arquitectónicas duráveis, racionalidade funcional, boa pormenorização e qualidade de construção , com particular atenção para o conforto ambiental, bons isolamentos, baixos consumos energéticos e utilização de energias alternativas .

A fim de garantir uma qualidade constante e um melhoramento contínuo dos desempenhos, o gabinete iniciou em 2001 um processo de certificação ISO 9001 (“Bureau Veritas Quality International”). Conseguida a certificação, que atesta que o sistema de trabalho posto em prática é eficiente e respeita as exigências da norma, o gabinete, graças ao sistema de controle permanente pode tirar conclusões de cada projecto terminado e assim progredir. As auditorias anuais que se seguem à certificação inicial levam a que não se repouse sobre os louros conseguidos e que se tente melhorar constantemente a qualidade da prestação de serviços, o que tem permitido renovar continuamente esta certificação de qualidade internacionalmente reconhecida.

Established in 1980 in the city of Luxembourg, the workshop of Ballini, Pitt & Partners has about twenty collaborators and boasts a vast output of work at the international level.

The founders, Roger Pitt (who graduated in Architecture from Sheffield University (UK) in 1977) and Gilbert Ballini (Institut Supérieur d’Architecture de Liège (Belgium), 1978), have been, from the outset, a defining force for projects based on architectonic solutions that are durable, functionally rational, and well built with attention to detail – all with a particular emphasis on environmental comfort, excellent insulation, energy-efficiency, and recourse to alternative energies.

With the goal of ensuring continued quality and improvement in meeting challenges, in 2001 the workshop initiated an ISO 9001 certification process, [Bureau Veritas Quality International]. Having obtained the certification, which attests to the workshop’s efficiency and adherence to norms, the workshop remains under constant scrutiny regarding every project – those in progress, and those completed. An annual audit that follows up the initial certification ensures that the workshop does not rest on its laurels – but that, instead, it remains ever vigilant to quality control and quality service, constantly “re-earning” its badge of international distinction.

